



All numerical values are in metric units [with U.S. customary units in brackets]. Dimensions are in millimeters. Unless otherwise specified, dimensions have a tolerance of ± 0.13 [$\pm .005$] and angles have a tolerance of $\pm 2^\circ$. Figures and illustrations are for identification only and are not drawn to scale.

1. INTRODUCTION

The Solderless LED Socket, Type CM provides an integrated electrical and optical solution for the CREE XLAMP MP-L LEDs. The socket enables power to be brought to the LED by using either a LED-to-board solution or a LED-to-wire solution. The socket also has features to mount the TYRA Series of reflectors from LEDIL. The Solderless LED Socket is mounted using three No. 4 or M3 screws.

The LED-to-wire solution enables customers to bring power by using the MiniCT connector which plugs into the socket. The board-to-board solution enables power to be brought to the LED by providing an electrical connection between the electrical pads on the LED substrate and pads on the printed circuit (pc) board. The LED to inverted wire solution enables the customer to bring power from underneath the pc board by wiring the MiniCT connector which plugs into the socket. Refer to Application Specification 114-5245 for the MiniCT connector.

When corresponding with personnel, use the terminology provided in this specification to facilitate your inquiries for information. Basic terms and features of this product are provided in Figure 1.

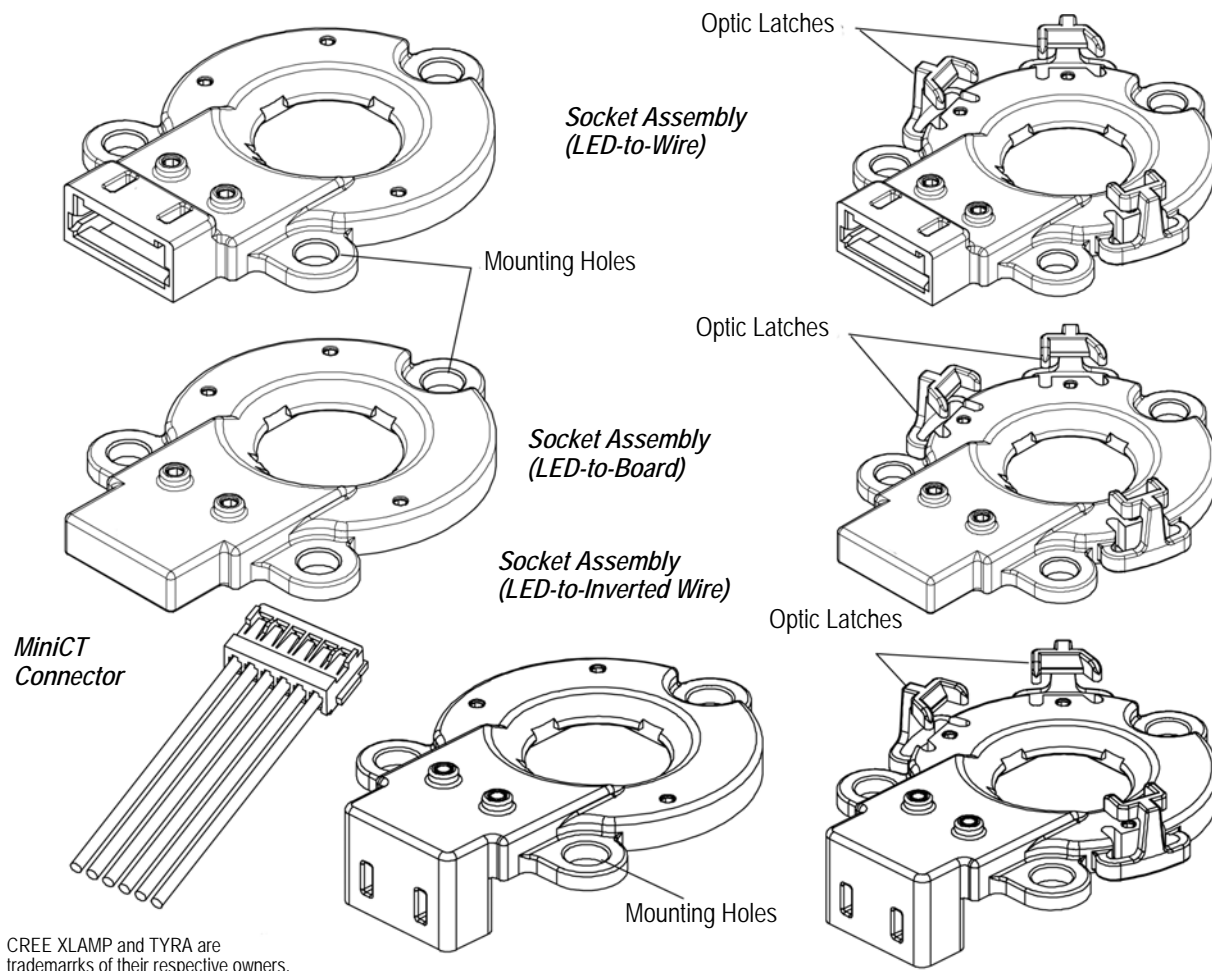

CREE XLAMP and TYRA are trademarks of their respective owners.

Figure 1

2. REFERENCE MATERIAL

2.1. Revision Summary

The new company logo was applied to this specification.

2.2. Customer Assistance

Reference Base Part Number 2106946, and Product Code L836 are representative numbers of the Solderless LED Socket, Type CM. Use of these numbers will identify the product line and expedite your inquiries through a service network established to help you obtain product and tooling information. Such information can be obtained through a local company representative or, after purchase, by calling the Tooling Assistance Center or Product Information number at the bottom of page 1.

2.3. Drawings

Customer drawings for specific products are available from the service network. The information contained in customer drawings takes priority if there is a conflict with this specification or with any other technical documentation supplied by the company.

3. REQUIREMENTS

3.1. Safety

Do not stack product shipping containers so high that the containers buckle or deform.

3.2. Storage

A. Shelf Life

The Solderless LED Socket should remain in the shipping containers until ready for use to prevent deformation. The socket should be used on a first in, first out basis to avoid storage contamination that could adversely affect performance.

B. Chemical Exposure

Do not store the socket near any chemical listed below as they may cause stress corrosion cracking.

Alkalies	Ammonia	Citrates	Phosphates	Citrates	Sulfur Compounds
Amines	Carbonates	Nitrites	Sulfur Nitrites		Tartrates

3.3. Features

The Solderless LED Socket has a pocket in the housing which captures the LED substrate and enables the socket to be properly aligned with the LED. The socket is offered with and without latches for the optics. Sockets without the latches can be used by customers who do not intend to use an optic or want to use their own optic. The socket has three mounting holes and can be mounted using three No. 4 or M3 screws.

3.4. PC Board Layouts

A. Material

The pc board material shall be glass epoxy (FR-4, G-10) or metal--clad pc board. Contact the Product Information Center or the Tooling Assistance Center at the number listed at the bottom of page 1 for suitability of other board materials.

B. Tolerance

The maximum bow of the pc board shall be 0.03 mm over the length of the connector.

C. Layout

The mounting holes in the pc board must be precisely located to ensure proper placement and optimum performance of the connector. See Figure 2.

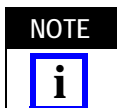
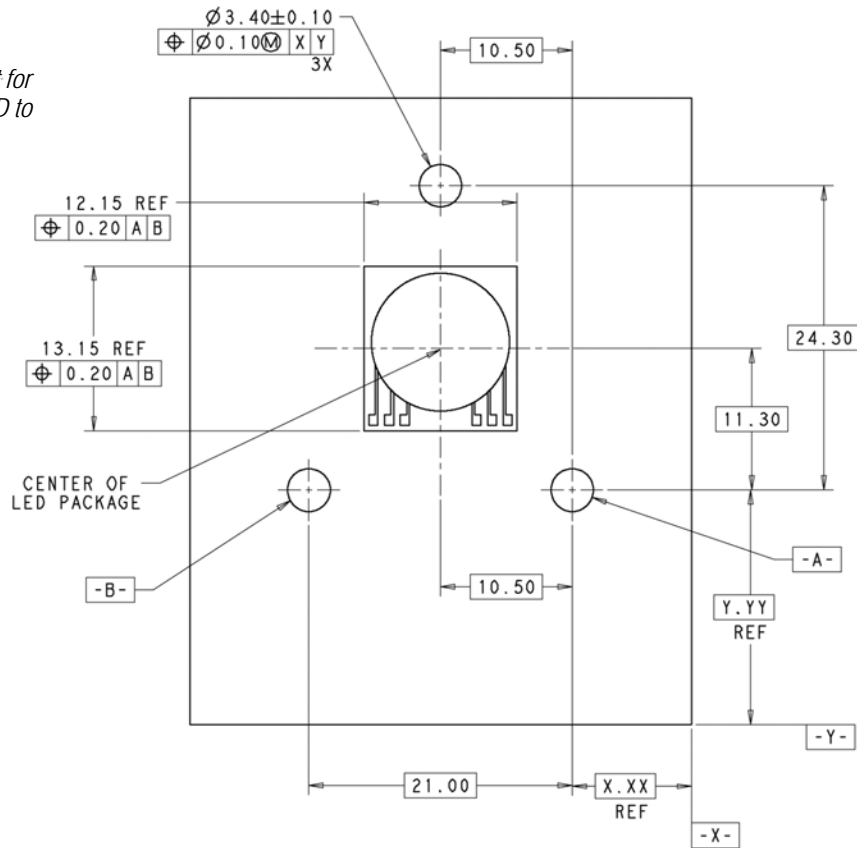

Figure 2 represents a typical pc board layout for this product. For dimensions and hole pattern layout for specific product, obtain the appropriate customer drawing through your company representative or refer to the telephone numbers at the bottom of page 1.

PC Board Layout for Mounting the LED to the Wire Socket



Heat Sink Layout for Mounting the LED to the Wire Socket

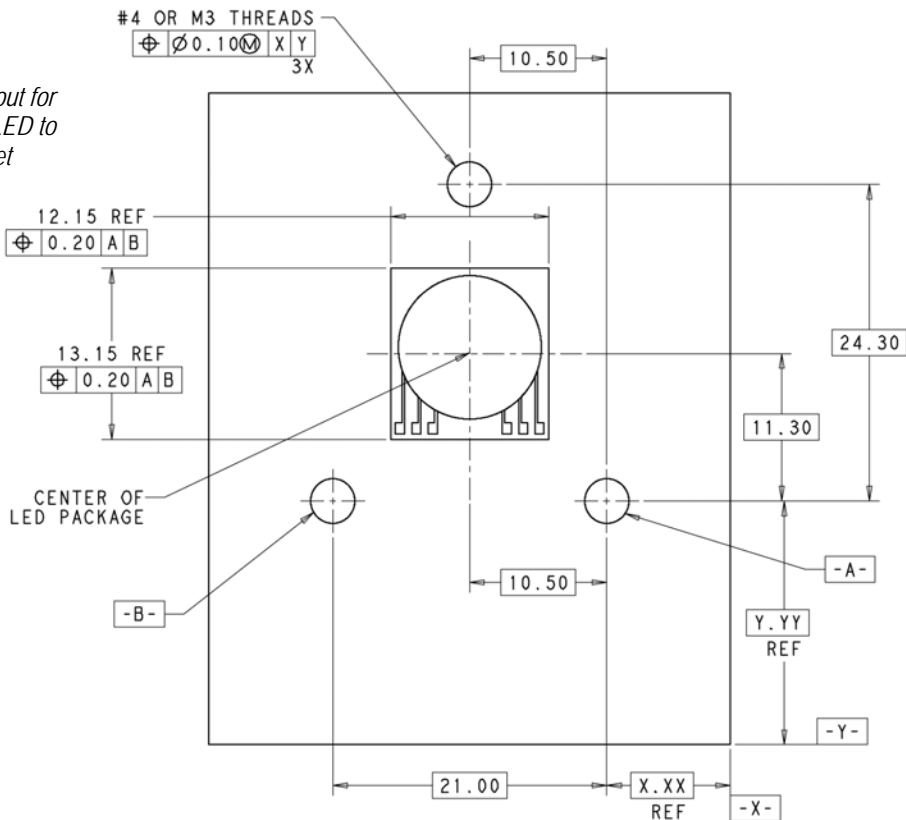
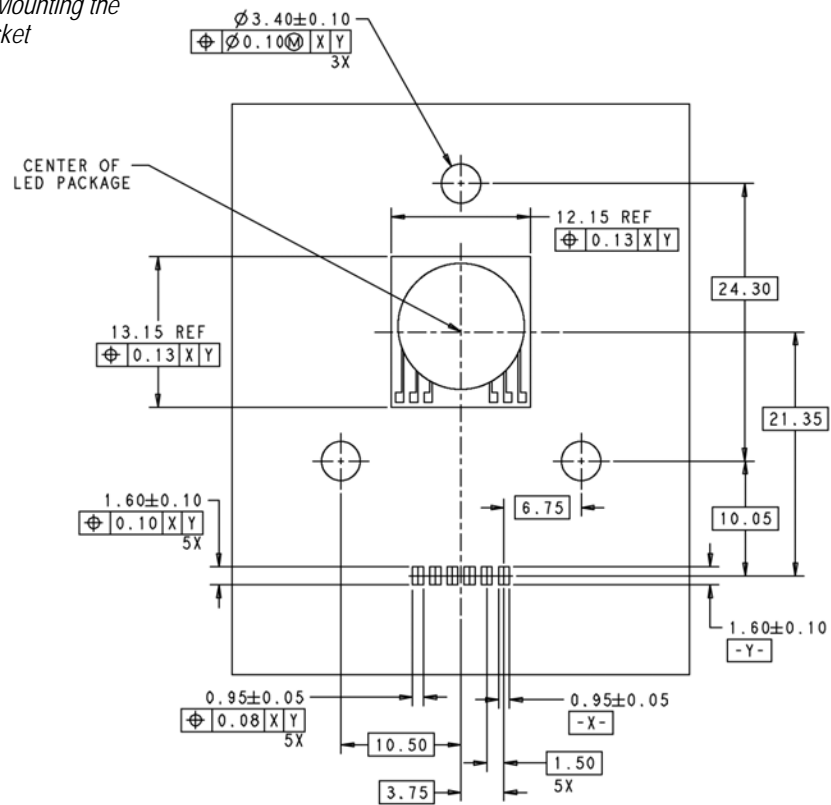

Figure 2 (Cont'd)

PC Board Layout for Mounting the LED to the Board Socket



PC Board Layout for Mounting the LED to Inverted Wire Socket

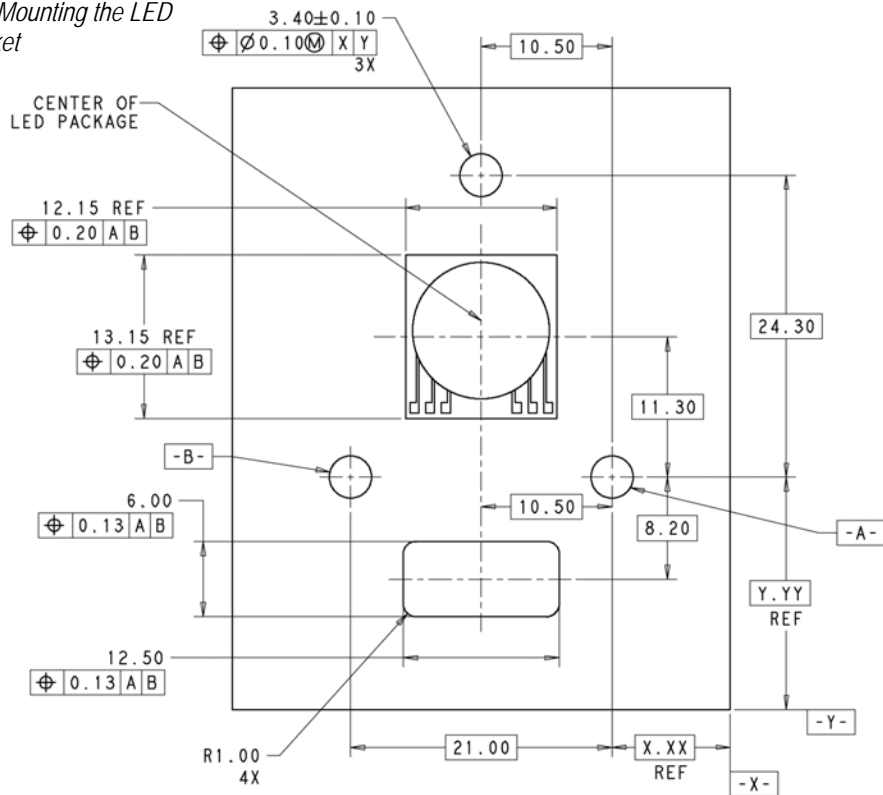

Figure 2 (End)

3.5. Mounting the LED

Instructions for mounting the LED can be obtained from CREE. See Figure 3.

NOTE

The Solderless LED socket will accommodate post reflow bond line or thermal epoxy thickness ranging from 3 to 5 mils.

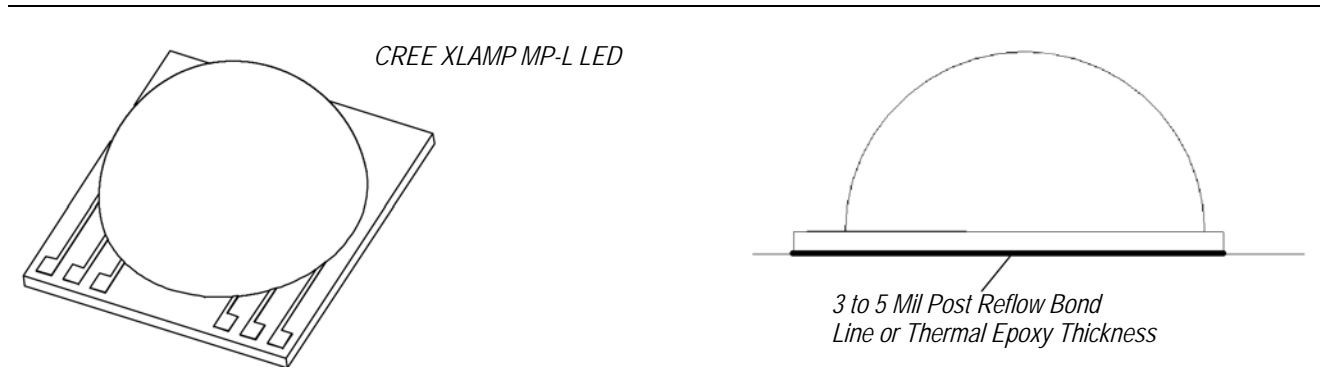

Figure 3

3.6. Mounting the Solderless LED Socket

Once the LED has been mounted (either by soldering it or by using a thermal epoxy), the socket is placed over the LED substrate. The socket has a pocket in the base which helps align it with the LED substrate. Using the openings in the socket, ensure that it is properly aligned. Once the socket has been aligned gently press it down and screw it in place. The socket can be mounted using three No. 4 or M3 screws. See Figure 4. **Tighten the screws to a torque of 0.28 to 0.45 N-m [2.5 to 4.0 in.-lbf].**

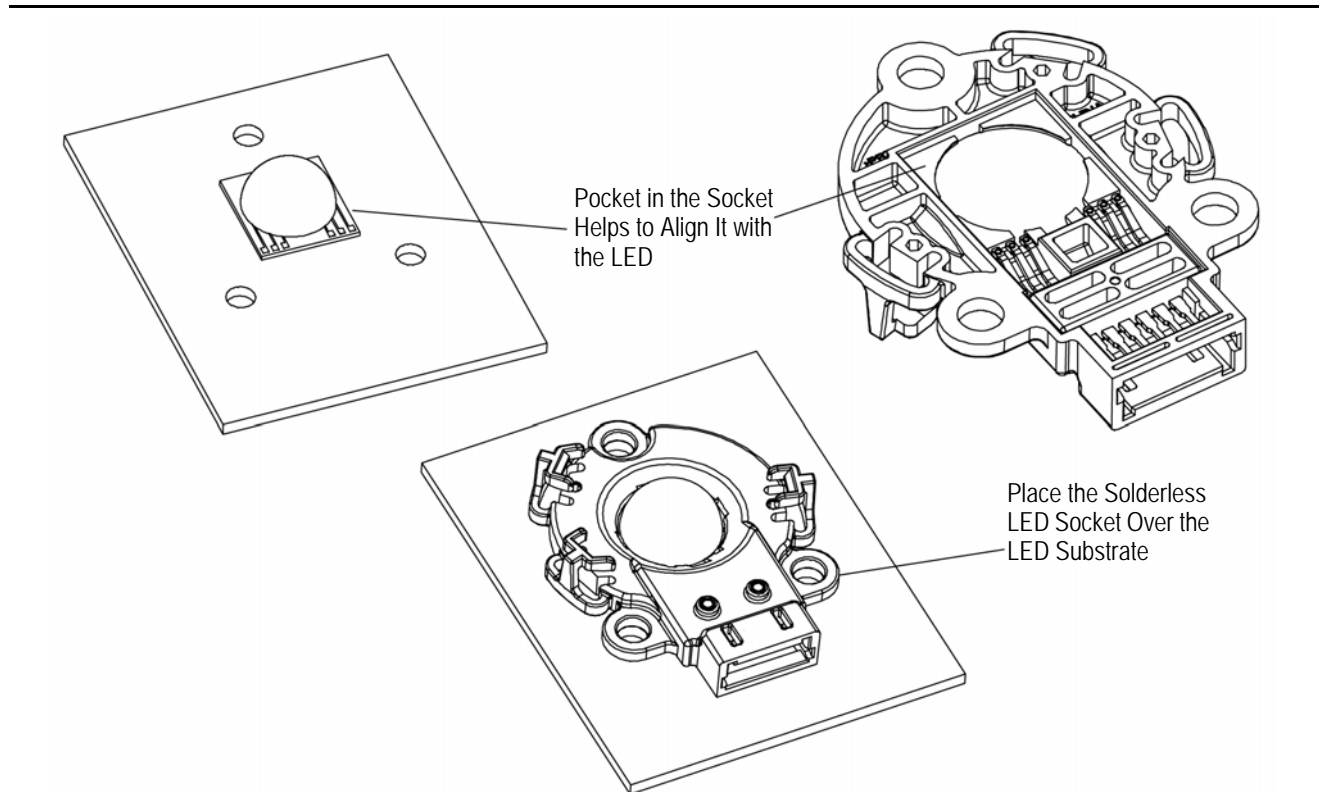

Figure 4 (Cont'd)

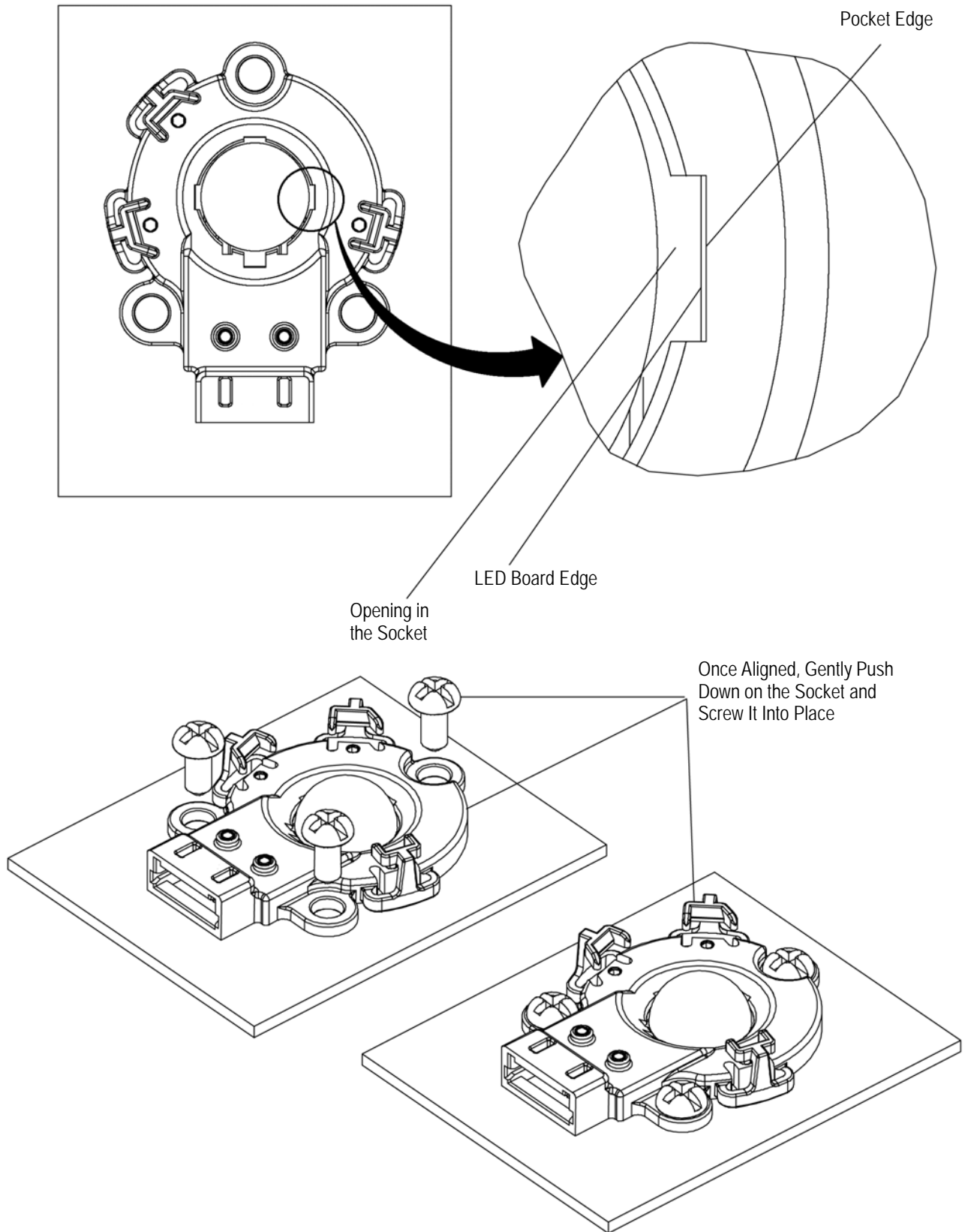

Figure 4 (End)



When pushing down on the socket, care must be taken to not damage the LED and the latches on the socket.



To protect against corrosion, screws from ferrous metals (other than stainless steel) should be zinc plated or have an equivalent protective coating.



The company recommends using pan head screws. The use of flat head screws is not recommended.

3.7. Mounting the LEDIL Optics

The Solderless LED Socket has snap features which allow for easily attaching the TYRA series of optics from LEDIL.



The socket must be secured in place with the screws before the optics can be attached.

To attach the optics, align the snap features on the socket with corresponding features on the optics. Once aligned, push the optic down until the latches have snapped into place. See Figure 5.

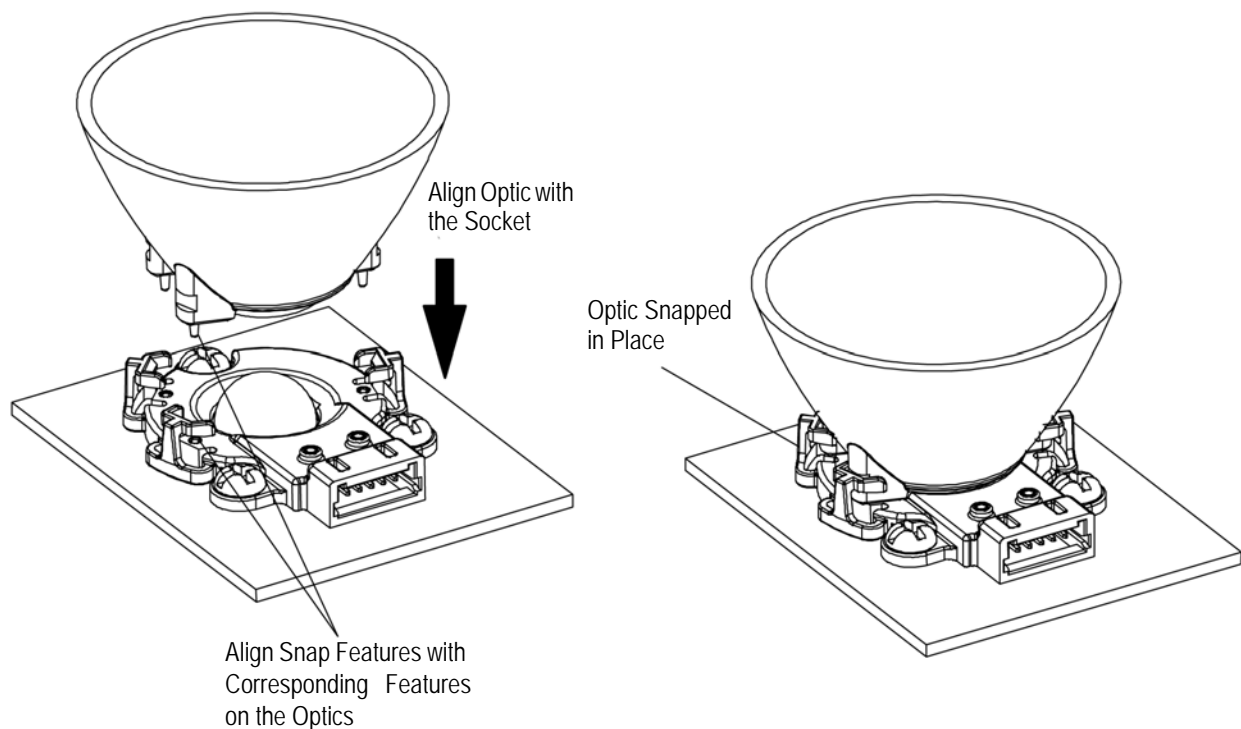

Figure 5



If the optic needs to be removed, pull the optic in the upward direction. Do NOT twist the optic.

3.7. Repair/Replacement



Damaged parts should not be used. Such components should be removed, discarded and replaced with new components.

4. QUALIFICATION

The Solderless LED Socket, Type LS is recognized by Underwriters Laboratories Inc. UL/CSA International, in File E28476, Vol. 10, Section 9.

5. TOOLING

No tooling is required.

6. VISUAL AID

The illustration below shows a typical application of this product. This illustration should be used by production personnel to ensure a correctly applied product. Applications which DO NOT appear correct should be inspected using the information in the preceding pages of this specification and in the instructional material shipped with the product or tooling.

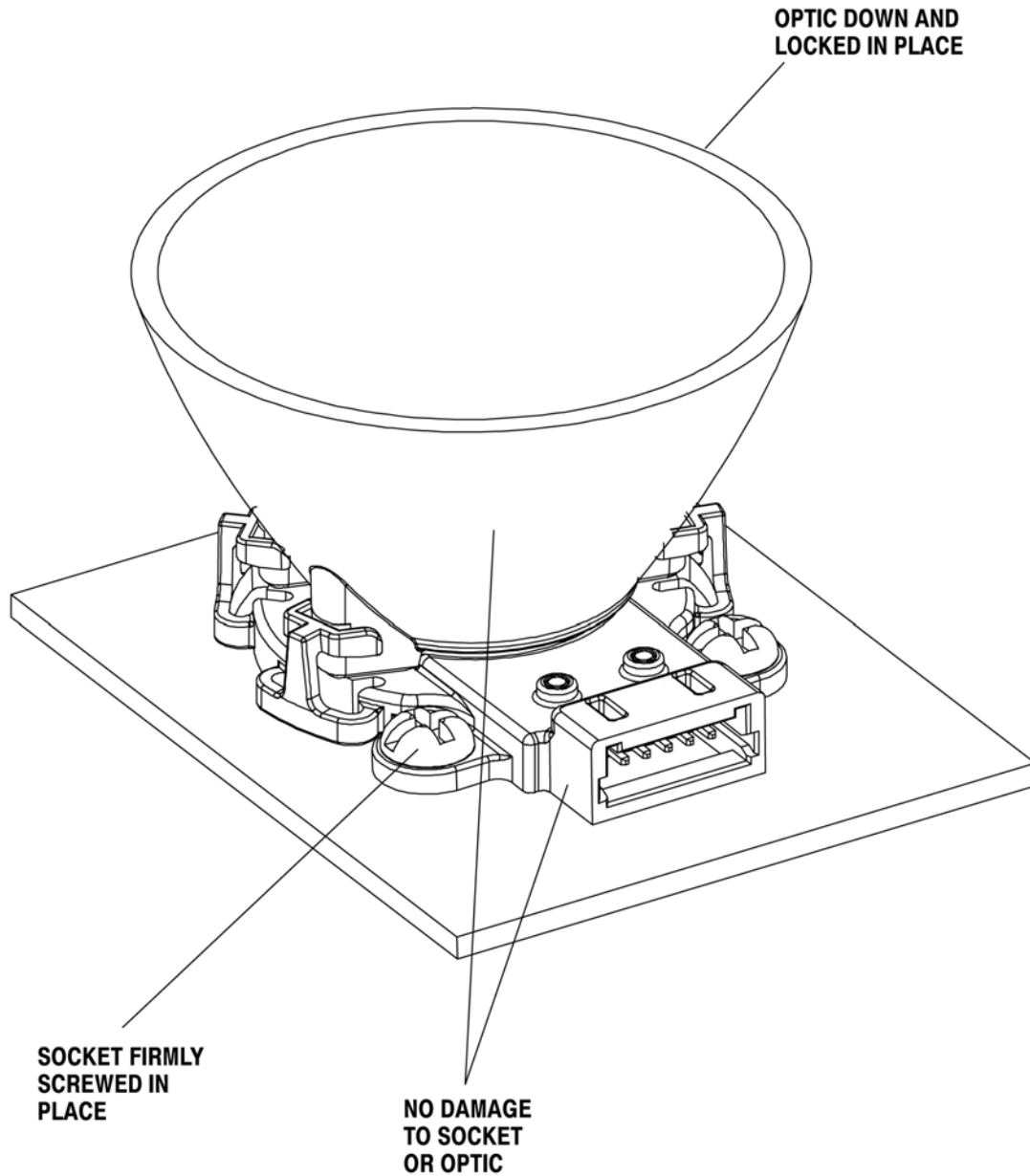

FIGURE 6. VISUAL AID